



LINEAR AIR TRACK SUB BASE - assembly kit 2M or 2.5M long

MF0105-005 base & kit for a 2.5m long Air Track **MF0107-005** for 2m Air Track

DESCRIPTION:

The Sub Base is a strong length of special tubing that is attached to the Air Track by sets of adjustable studs that can alter the straightness of the Air Track tube. For installations where the straightness is of special importance, it is recommended to use a sub base under the track.

PACKING:

The rods and knobs are stored in a bag down the centre of the sub base rail. Remove the end cap, remove the bag and replace the end cap.

MF0105-005 or MF0107-005

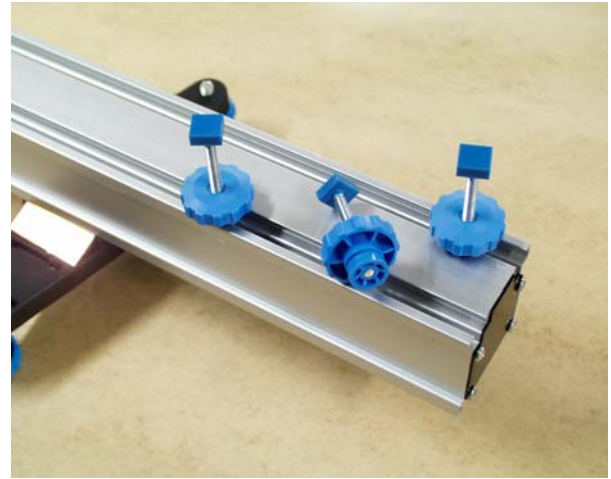

Notice that the adjusting feet are removed from the Air Track and fitted instead to the Sub Base tube. See the studs that engage in the underside of the track and also in the upper side of the sub base so that the track can be raised or lowered relative to the sub base rail.

THE KIT COMPONENT PARTS ARE:

- **MF0105-005:** 2.5m long Sub Base tube with end caps. With 12x threaded studs with square heads and round knobs for level adjustment.

OR.....

- **MF0107-005:** 2m long Sub Base tube with end caps. With 10x threaded studs with square heads and round knobs for level adjustment.

Designed and manufactured in Australia by Industrial Equipment and Control Pty Ltd

Distributed by

Scientrific Pty Ltd

ABN 55 056 072 694

PO Box 420 Yamba NSW 2464
Phone (02) 6645 8111 Fax (02)66458125



The image below shows an Air Track with a Sub Base fitted.

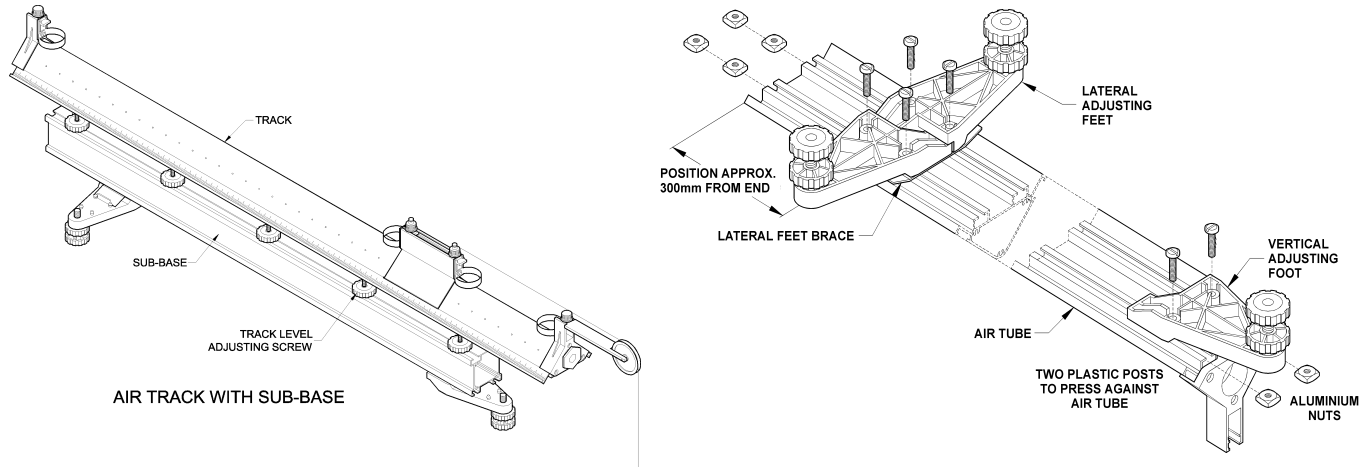

Sub Bases are used normally on long Air Tracks or where the track straightness must be exact. Sections of the track can be raised and lowered slightly by adjusting the special screws. The feet fit to the Sub Base in the same manner as they fit to the Air Tube.

ASSEMBLY PROCEDURE TO ATTACH FEET TO SUB BASE:

- Lay the Sub Base tube on the table with the pair of smaller slots uppermost.
- Note the pair of plastic feet assembled back to back through the steel stiffening plate.
- Take these feet, loosen the 4x square nuts but do not remove them.
- Slide the nuts up the slots so that the feet are protruding from either side of the sub base. When they are about 300mm from one end of the sub base, tighten the 4x screws firmly.
- Take the third foot and slide the two aluminium nuts along the slots at the opposite end of the base so that the foot protrudes directly from the end of the sub base. **Be sure the foot is slid back far enough so that the small upstanding rib is positioned between the slots of the tube to prevent the single foot from twisting.** Tighten the two screws firmly. The foot should be very rigid.
- Invert the sub base so it rests on the table on its 3 adjustment screws.

ASSEMBLY PROCEDURE TO ATTACH THE SUB-BASE TO AIR TUBE:

- Take the special adjustment screws and slide the square heads into the slots in the underside of the air track tube. Be sure that half of the quantity is placed into each slot.
- Turn the adjustment knobs on the screws with the serrated end closest to the air tube. Screw them on so that the face of the knobs with the groove are all exactly flush with the tip of the screw (all exactly the same distance from the underside of the track).
- Take the Sub Base, invert it and with somebody assisting you, slide the grooved end of each adjustment knob into the 2 large slots in the Sub Base. Gradually work all the knobs down the slots until they are all engaged into the Sub Base slots. Then slide the screws individually along the slots in the track and base until they are evenly spaced in pairs along the tube. See Illustration of the Air Track with Sub Base fitted.

Designed and manufactured in Australia by Industrial Equipment and Control Pty Ltd

Distributed by

Scientrific Pty Ltd

ABN 55 056 072 694

PO Box 420 Yamba NSW 2464

Phone (02) 6645 8111 Fax (02)66458125



THE ALIGNMENT PROCEDURE OF THE SUB-BASE AND THE AIR TUBE

- With the Air Track attached to the Sub Base, apply the air at a low speed so that a glider will just float on the track. Adjust the knobs on the 3 feet on the Sub Base until the track is close to level where the glider almost rests without sliding either direction.
- Try the glider at different places along the track and decide which parts of the track are slightly high or slightly low.
- Where the track is slightly low, slightly adjust the knobs joining the track to the base so that the low part of the track is pushed **slightly** upwards. Re-adjust the main foot at the end of the Sub Base to make the glider rest without sliding either direction.
- Again find any places that are either high or low and adjust the knobs again to either **slightly** push the track upwards or **slightly** pull the track downwards.
- When this procedure is finished, the glider should be close to not sliding either direction at all places along the track. Once the track is held straight, this procedure should not ever require repeating.
- Be sure that all the adjustment screws are either slightly pushing or pulling and do not leave loose knobs anywhere along the track.

Designed and manufactured in Australia by Industrial Equipment and Control Pty Ltd

Distributed by

Scientrific Pty Ltd

ABN 55 056 072 694

PO Box 420 Yamba NSW 2464
Phone (02) 6645 8111 Fax (02)66458125